

FUJITEC
www.fujitec.com

ELSIA
High Speed Elevator



“Made in Fujitec”

Fujitec is Creating and Leading the
New Global Standard for Elevators.



By manufacturing safe and reliable elevators in-house, we are building trust with people around the world.

Fujitec's "Global Common Components" are used in the ELSIA brand. The quality of components, such as traction machines, elevator controllers, and operating fixtures, is controlled through Fujitec's integrated system of global quality management. Elevators with the same high quality will be provided by Fujitec's global supply chain under the concept of "Made in Fujitec."



Excellent Performance

The permanent magnetic synchronous gearless motors, which have been designed and developed by Fujitec, provide the utmost reliability and excellent driving performance. These motors reflect 73 years of accumulated know-how through our technological achievements in elevator manufacturing, which spans from product designing to fabrication.



Reliable Operation

Since all control-related components, ranging from control circuits to inverters, were independently developed by Fujitec, highly reliable elevator operation is established. In the event of an elevator malfunction, the elevator control system assembled with our components immediately detects the malfunction and maintains efficient and stable operation.

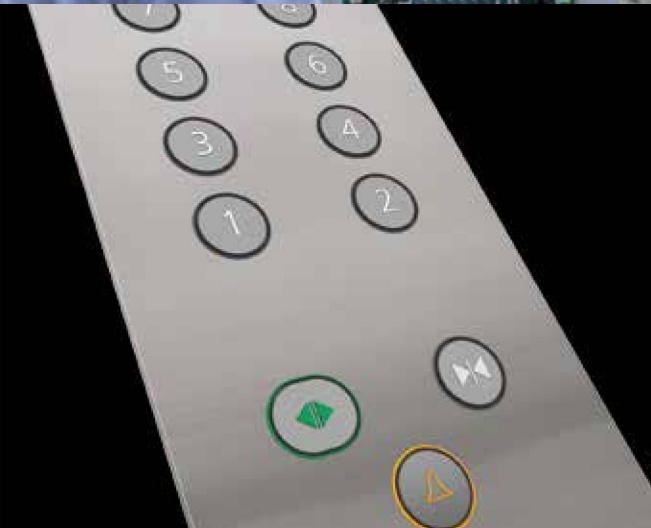

Universal Design

Under our universal designs, aesthetically refined buttons, displays, etc. on elevator operating fixtures are highly visible. Passengers will have a superb and comfortable riding experience.



Styles

Various decoration styles for the elevator interior and landing floors are offered by Fujitec. Customers can select the most suitable decorative materials for car panels, car ceilings, car floorings, car operating boards, and landing fixtures.



CONTENTS

- Excellent Performance05
- Reliable Operation.....09
- Universal Design..... 12
- Styles..... 13
- Systems & Functions.....27
- Planning.....31
- Related Data.....32
- Work Done by Others33

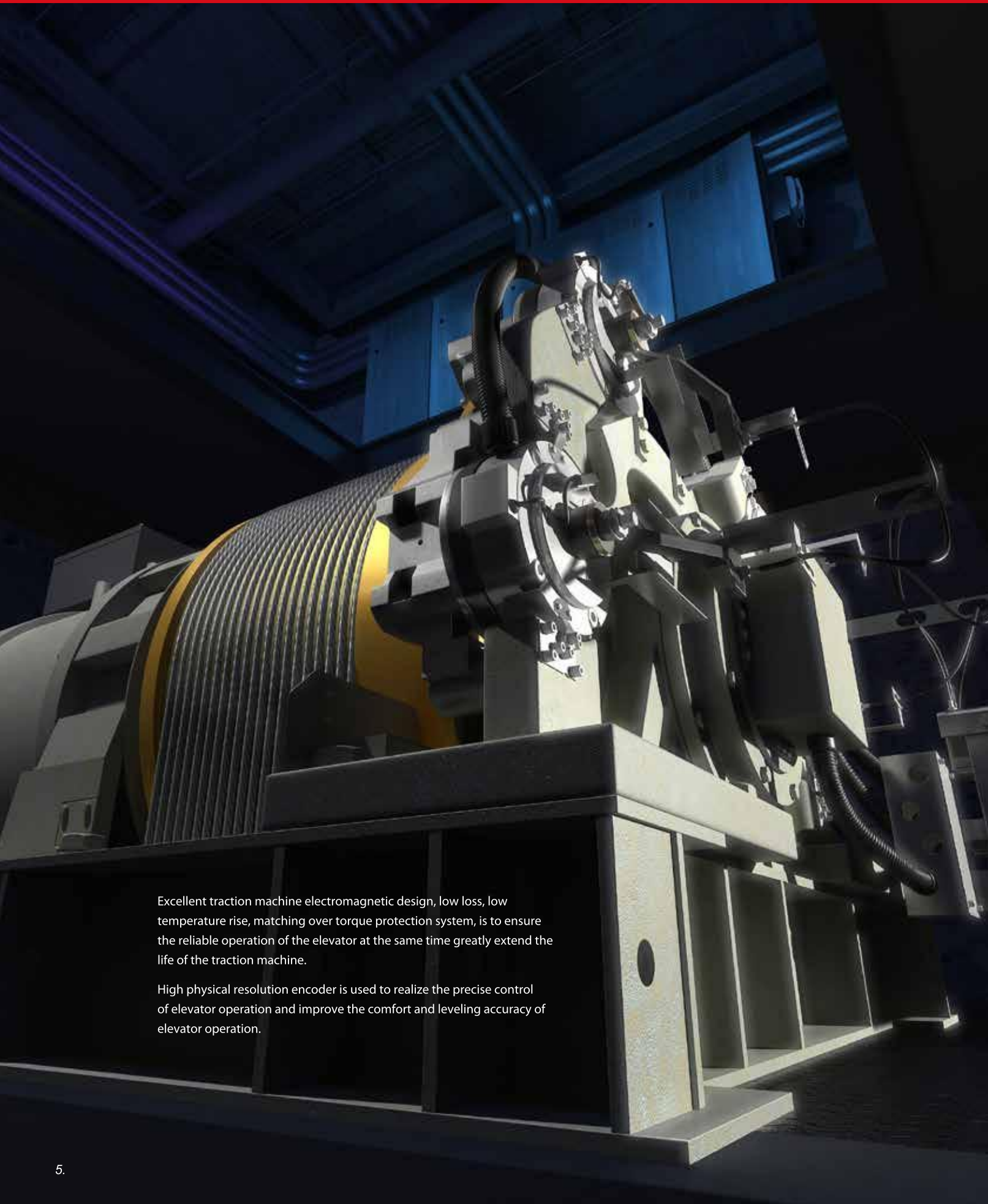

Excellent traction machine electromagnetic design, low loss, low temperature rise, matching over torque protection system, is to ensure the reliable operation of the elevator at the same time greatly extend the life of the traction machine.

High physical resolution encoder is used to realize the precise control of elevator operation and improve the comfort and leveling accuracy of elevator operation.

Driving System

The drive system of Fujitec high-speed elevators features a PM gearless motor. Through our R&D work which utilizes state-of-the-art CAE technologies and our own technical expertise accumulated over many years as a specialized elevator manufacturer, we have achieved in developing a compact traction machine where the machine weight is reduced by up to 30% compared to the machine weight of our conventional models.

Furthermore, the performance of the traction machine motor has also been improved by in-depth analysis and optimization of the magnetic circuit.

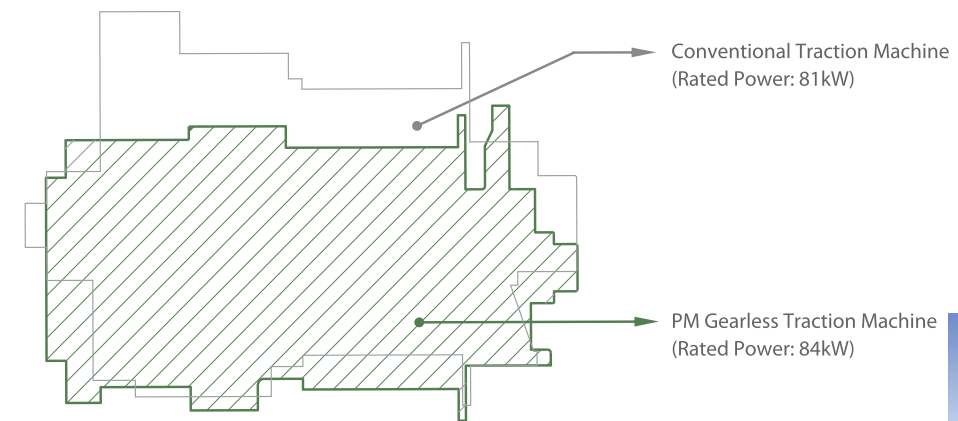

Appearance comparison with conventional Traction Machine
This machine is applied to the elevator with capacity 2000kg and speed 480m/min

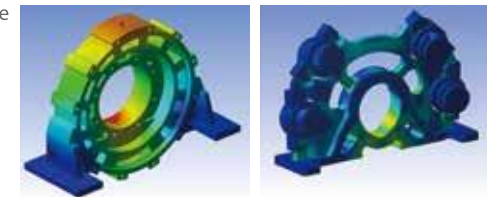

Structural Analysis utilized CAE Technology

Ultra-slim Door Operator with Permanent Magnetic Synchronous Motor

Fujitec new ultra-thin permanent magnet synchronous door machine, operates smoothly. Compared with the traditional asynchronous motor, the permanent magnet synchronous motor can save 35% energy.

On the basis of using Fujitec mature transmission form, the structure is improved, the thickness of the door operator is reduced by 50%, and the space of the shaft is effectively saved.

The key parts of the door operator are set in the opening area under the support frame, which can effectively reduce the risk of trampling and foreign matter entry, and is convenient for inspection and maintenance.

35%*

Energy saving by comparing with traditional asynchronous motor

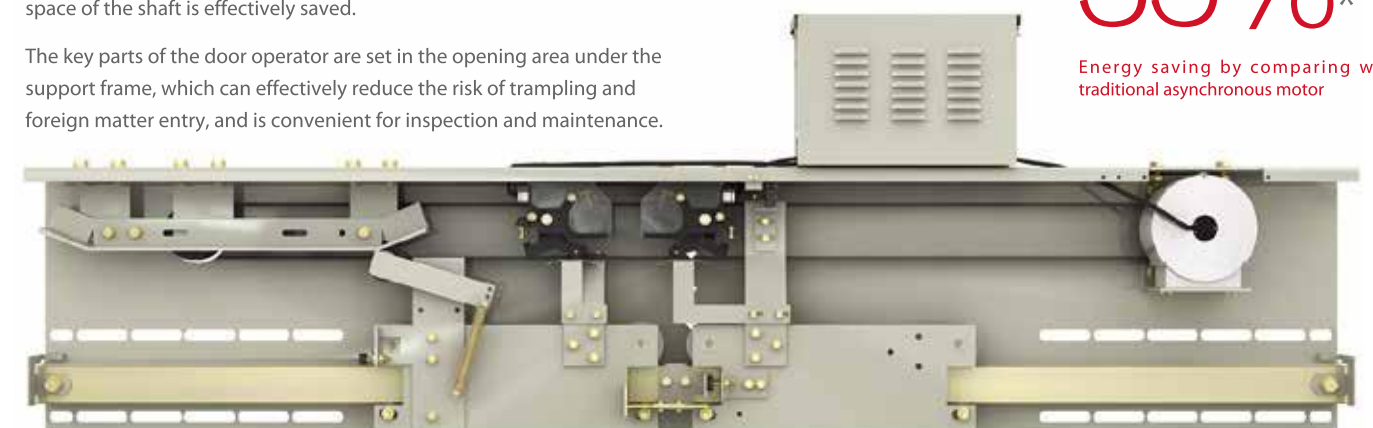

Excellent Performance

Advanced Frequency Conversion Control System to Realize Energy Saving

The drive system of Fujitec high-speed elevators features a PM gearless motor. Through our R&D work which utilizes state-of-the-art CAE technologies and our own technical expertise accumulated over many years as a specialized elevator manufacturer, we have achieved in developing a compact traction machine where the machine weight is reduced by up to 40% compared to the machine weight of our conventional models.

Furthermore, the performance of the traction machine motor has also been improved by in-depth analysis and optimization of the magnetic circuit.

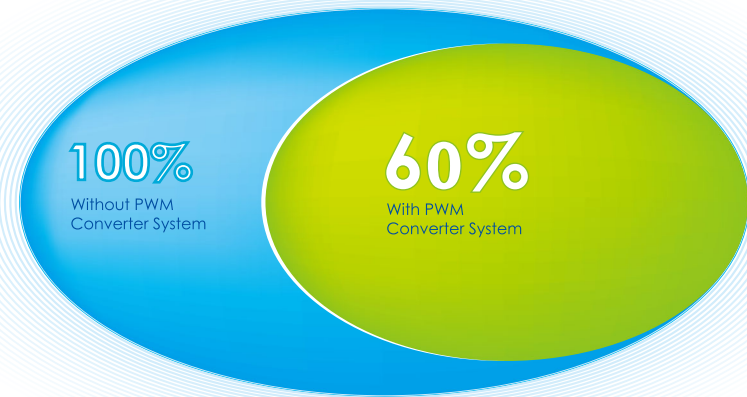

ENERGY SAVING EFFECT DIAGRAM

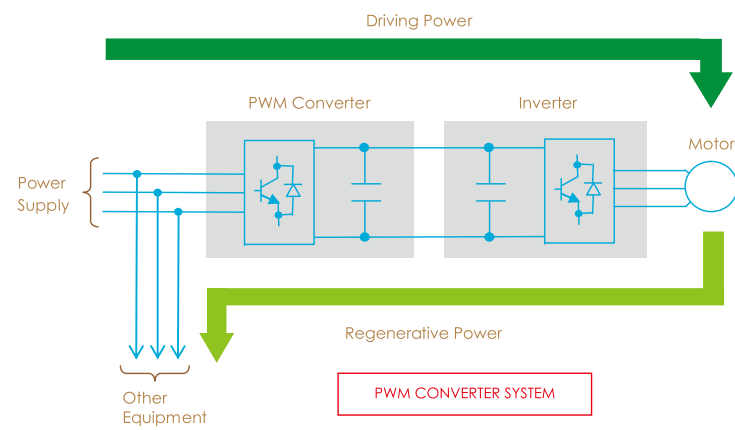

Comparison of Average Daily Waiting Time

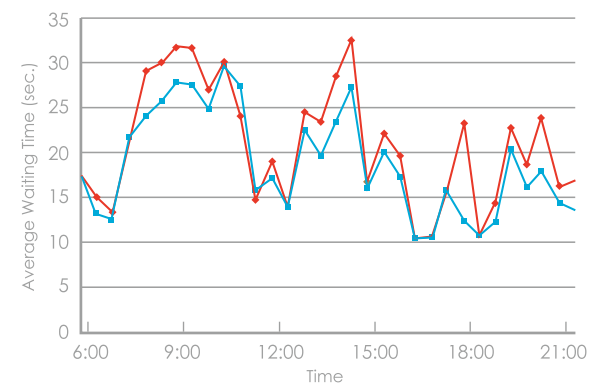

— Conventional Group Supervisory Control System
— Virtual Passenger Optimization Method

* The graph shows the results of a simulation to reproduce the daily traffic in an actual high-rise condominium having three elevator units and 33 stops.

Comparison of Average Journey Time During Up-peak Period

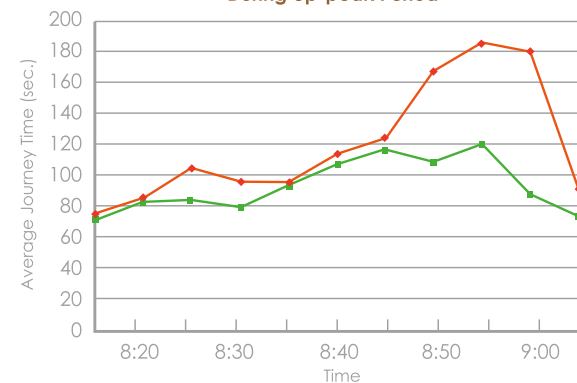

— Conventional Group Supervisory Control System
— Destination Reservation Guidance System

* The graph shows the results of a simulation to reproduce the traffic during the up-peak period in an office building having six elevators and 20 stops.

Virtual Passenger Optimization Method New-Generation Elevator Group Supervisory Control System

FLEX-NX SERIES

Fujitec has newly employed the Virtual Passenger Optimization Method, which virtually calculates the long-range waiting time of each passenger, based on extrapolated passenger arrival rates by travel direction at each floor from past learned data in order to execute the group supervisory control.

The system probabilistically extrapolates the number of passengers who arrive later at a stop where a hall call had already been registered or passengers who arrive at a stop where no hall call had been registered and then the system comprehensively calculates the passenger waiting time.

With such a design, it is possible to accurately reflect and predict the traffic situation of the whole building for the elevator traffic control, thereby enabling a reduction in the average daily waiting time for all passengers by up to 10%.



Comfort And Safety

Comfortable Ride

Handling the flowing air (a design factor) is essential for the elevator car in narrow shaft with ultra-high speed. Therefore, Fujitec elevator will use the experience and technology obtained from the joint research with DOME Co., Ltd. (a world-famous racing manufacturer) in the R & D of elevator, so as to minimize the impact of air flow.

The result is that the noise and vibration have been greatly improved, so as to realize the super-high ride comfort during high-speed operation.



Improvement of Riding Comfort (Horizontal Vibration)

As the only means of fast transportation in buildings, elevators need a higher degree of quiet and comfort.

Therefore, in the development and design stage of elevator equipment, Fujitec has been committed to meeting the customer's sense of experience. In terms of hardware, CAE technology is fully used in the research and development of components to reduce vibration, in order to ensure high operation efficiency and ride comfort. In terms of software, high operation efficiency and ride comfort can be achieved through the following ways; Direct leveling (without low speed crawling), vector control of high performance inverter and PWM motor with high response current control.

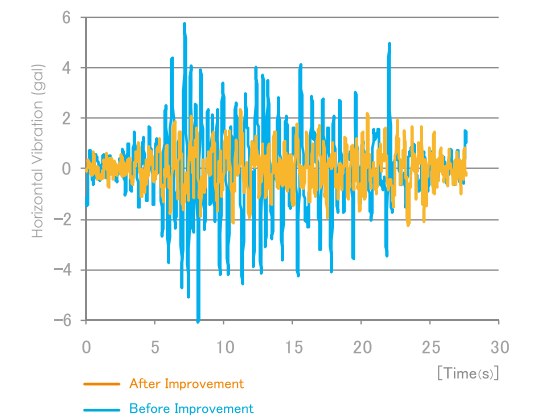

This data comes from the test report of Huasheng Fujitec Elevator Co.,Ltd.'s laboratory.

Reliable Operation

EZSHUTTLE

During rush hours in urban office buildings, many passengers occupy the lobby in a short period of time and then, rush to the elevators responding to their up/down hall call registrations.

Currently, a fully occupied elevator receives many car call registrations and must stop at many floors in order to complete all passenger service in its traveling direction. This elevator operation process causes a long riding time for passengers.

In an elevator operating system with EZSHUTTLE, Passengers are required to register their destinations at the elevator floors rather than conventionally registering them inside the elevator.

The EZSHUTTLE system then guides passengers to their assigned elevators, which will have been selected to minimize the number of destination stops based on the registered destinations.

This passenger guidance and elevator assignment provides passengers with uncongested elevator service and a reduction in passenger riding time by 50%* at peak travel periods.

*Based on comparisons of passenger riding time obtained under a conventional elevator operating system and that under a simulated EZSHUTTLE-equipped elevator operating system.



EZ- SHUTTLE

Conventional Elevator Operating System EZ- SHUTTLE

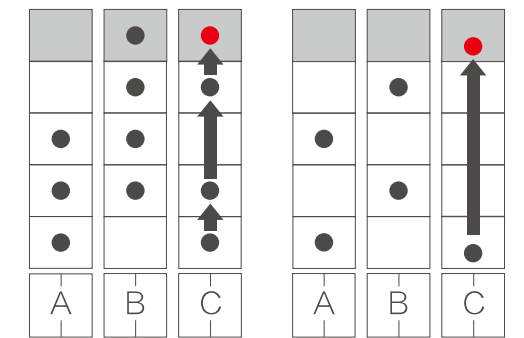

Riding Time Reduction by 50%



Before Elevator's Arrival
Passengers wait in front of their assigned elevators as indicated on the entry terminals.

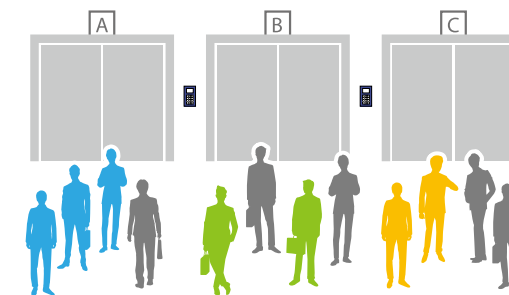

Riding the Elevator
Each group of passengers takes the elevator bound for their zoned destinations.

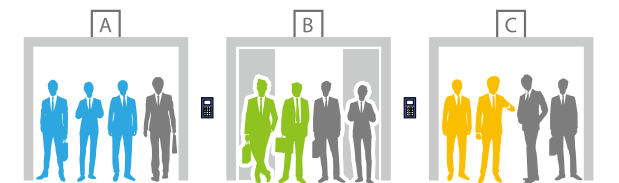

Conventional Elevator Operating System



Before Elevator's Arrival
After registering hall calls, passengers wait in front of the first responding elevator.

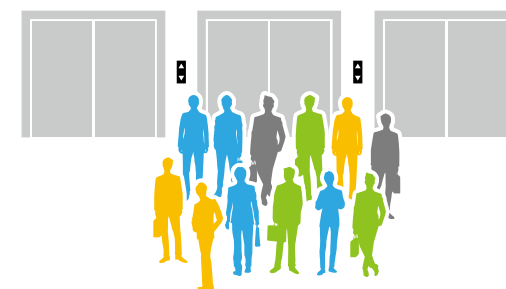

Riding the Elevator
Passenger going to different zones ride in the same elevator. Some passengers are left behind by the overcrowded elevator.



Reliable Operation



Car Door Anti Stripping Device

It can prevent passengers from falling into the shaft when the door is opened in the non unlocking area, and further ensure the safety of elevator passengers.



Impact Resistant Door System

The impact resistance of the landing door system is further strengthened, and the risk of falling into the shaft caused by the impact of the landing door system is effectively prevented, further ensuring the safety of elevator related personnel.



Unintended Car Movement Protection (UCMP)

A safety-purpose control circuit independent of the elevator operating system detects unintended movement of a car and prevents the car from moving from the floor with its doors open. This function increases passenger safety.

Distributed Control System

COP: Control Panel
COB: Car Operating Board
MIC: Microcomputer
IN: Hall Indicator

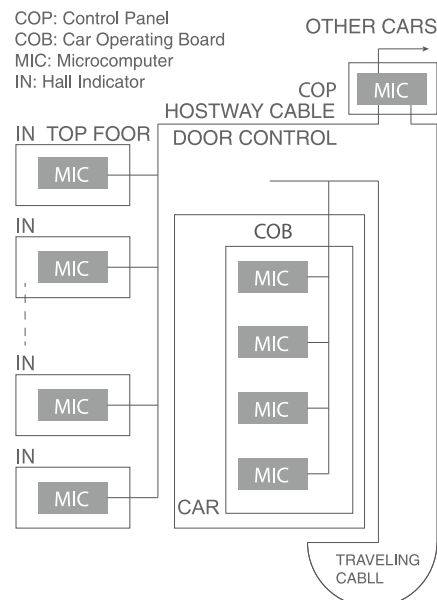

A 32-bit data bus provides high-speed and high-precision data transmission of input-output command signals between each microprocessor located in control panels, hall-call / car-call buttons, hall indicators and hall lanterns.

High-speed data transfer with multiple protocols enables large-scale data processing at ten times the normal speed. This also improves the ability to monitor elevator running speed, landing precision and operating reliability as well as input-output command signals of car operating fixtures and operation indicators.

The bus system is employed for data transmission between microcomputers located in every hall-call fixture, car operating board, and control panel. This bus system has strong protection against signal interference and has system-extending capability.

An elevator operation system with multiple microcomputers makes maximum use of a "Distributed Control System." Hall indicators, car operating boards, and control panels incorporate high-performance microcomputers. These independent microcomputers analyze elevator operating conditions utilizing self-diagnostic functions and implement immediate control of elevator operations. Also, data transmission buses between microcomputers increase data processing capability.

Universal Design

IONFUL

- Plasmacluster™* Ion Generating Device -

(Optional Specification)

Fujitec is the leading elevator company to have installed a Plasmacluster Ion generating device in an elevator. This device built in a car's ventilating unit disinfects airborne mold, bacteria, viruses, allergens, and odor molecules as well as creating clean air in the elevator which enhances passenger comfort.

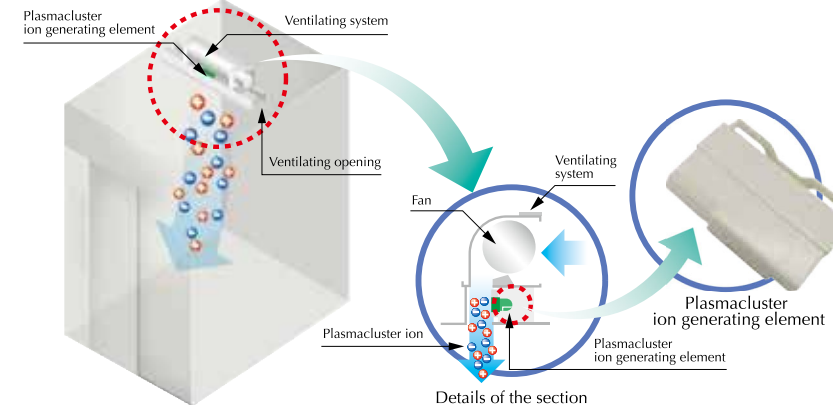

Plasmacluster is a trademark of sharp Coporation

Multi-Beam Sensor

Multi-beam Sensor emits multiple infrared beams, creating an invisible curtain covering the doorway. If any of the beams is interrupted, the closing doors will stop and reopen. This function results in a significantly higher detection rate of a passenger and/or an object in the doorway.



LED Down lights on Car Ceiling

For car ceiling lighting, Fujitec adopts LED downlights, which are long-lasting and energy-efficient. This adoption contributes to the protection of the environment.

	approx. 1,500 hours	approx. 20,000 hours	approx. 13 times
Lifetime			
Wattage	90W	9W	1/10 (one-tenth)



VONIC (Automatic Voice Announcement System)

(Optional Specification)

A computerized voice system (English) provides passengers with timely information about car directions, car arrivals, door opening and closing, and emergencies, etc.

[At the customer's request, announcements in other languages can be added.]





CR-n1



Ceiling:	Stainless Steel with Mirror Finish(Frame) Ceiling Light(Central)
Walls,Transom:	Embossing, Stainless Steel with Mirror Finish, Titanium Gold and Wooden
Car Door:	Embossing, Stainless Steel with Mirror Finish& Titanium Gold
Fan:	Cross_Flow Fan
Floor:	Designed by PVC

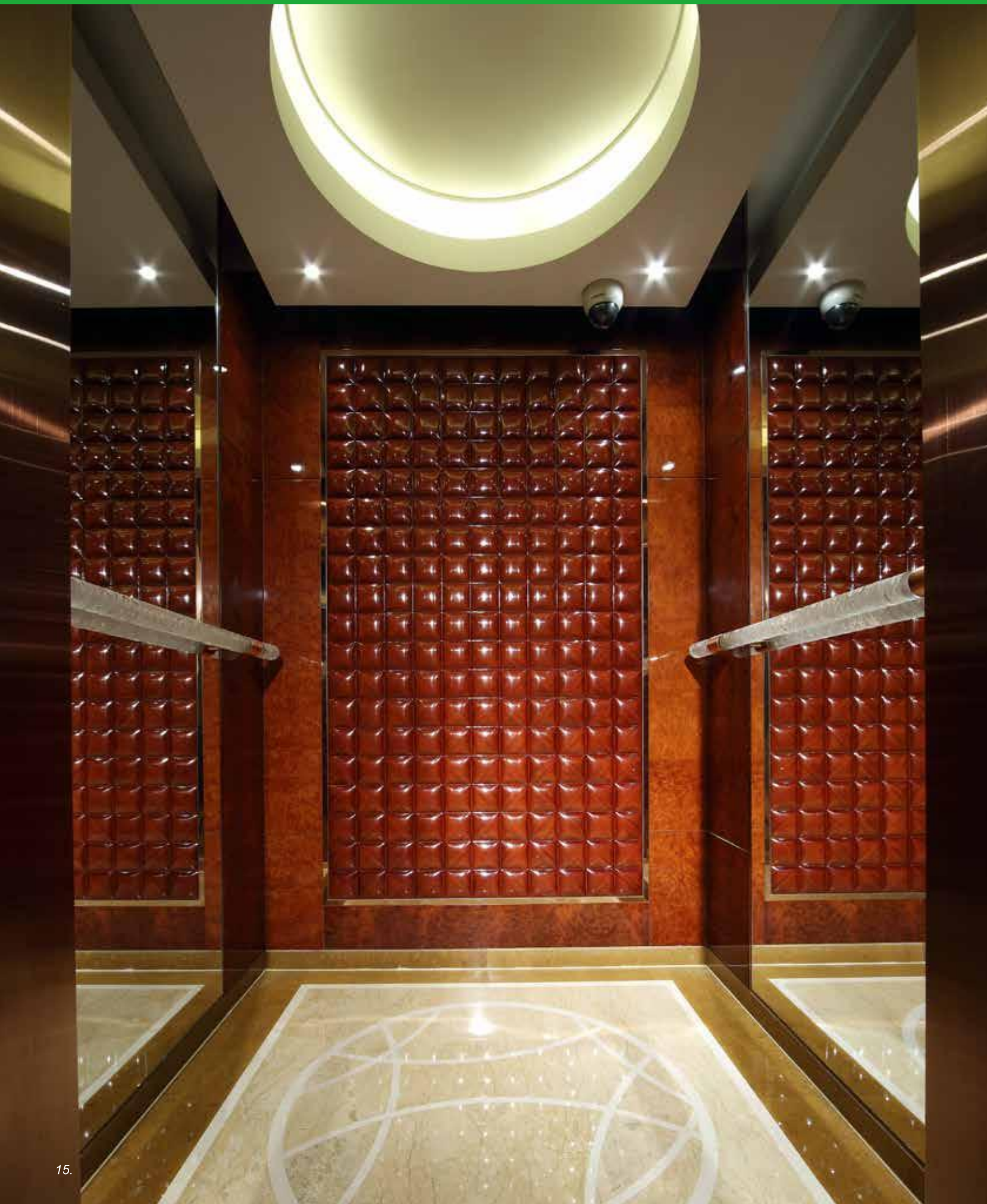

CR-n2



Ceiling:	Stainless Steel with Mirror Finish+light
Walls,Transom &Door:	Stainless Steel with Mirror, Etching, Stainless Steel with Hairline Finish, Titanium- Black
Fan:	Cross_Flow Fan
Floor:	Designed by PVC

CR-n3



Ceiling:	Stainless Steel with Mirror Finish(Frame) White Transparent Board(Sides)
Walls,Transom &Door:	Stainless Steel with Mirror Finish, Stainless Steel with titanium-Bronze, Sandblast Finish
Fan:	Cross_Flow Fan
Floor:	Designed by PVC

CR-n4



Ceiling:	Metal Paint (TE-f1) (CE-e2)
Walls, Transom & Door:	Stainless Steel with Hairline Finish
Mirror:	Stainless Steel with Mirror Finish
Fan:	Cross-Flow Fan
Handrail:	HR-a1
COB:	FX-k11
WCOB:	FX-g31
Floor:	Designed by PVC (BD-C1)
Sill:	Hard Aluminum Alloy
Kick Plate:	Stainless Steel with Hairline Finish



CE-e2

Arch-Shaped Part:
Milky-White Acrylic Sheet
Flat Panel:
Steel Sheet with Color Paint
Light:
LED (White)+ Downlight(3W, LED)
Emergency Light(4.5W, LED)

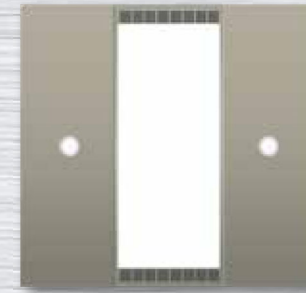

CE-c1

Arch-Shaped Part:
Milky-White Acrylic Sheet
Flat Part:
Steel Sheet with Color Paint
Light:
LED+ Downlight(3W, LED)
Emergency Light(5W,LED)



CE-c4

Flat Part:
Milky- white Acrylic Sheet with the
Crossed Triple Beam
Flat Panel:
Steel Sheet with Color Paint
Light:
LED (White)
Emergency Light(5W,LED)



CE-c7

Flat Part:
Milky-White Acrylic Sheet
Flat Panel:
Steel Sheet with Color Paint
Light:
LED (White)
Emergency Light(5W,LED)



CE-e4

Frame Part:
Stainless Steel with Hairline
Central Part:
Stainless Steel with Mirror
Milky- White Acrylic Sheet
Light:
LED(White)+ Downlight(2W, LED)
Emergency Light(4.5W, LED)

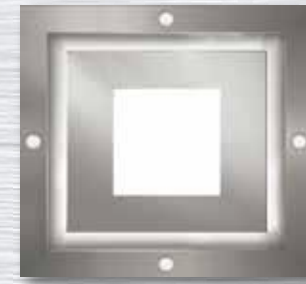

Note: Ceiling internal height will vary based on the ceiling types.

Standard Car Design:

Ceiling:	Metal Paint (TE-f1) (CE-e2)
Front Panel, Transom & Door:	Stainless Steel with Hairline Finish
Side Panel & Rear Panel:	Paint Finished Steel Sheet
COB:	FX-k1
Fan:	Cross_Flow Fan
Floor:	Designed by PVC
Sill:	Hard Aluminum Alloy
Kick Plate:	Stainless Steel with Hairline Finish

Noted: Standard car is designed to meet the secondary decoration by customer.



■ Standard ■ Optional

FX-k1



Faceplate: (Swing Type)
Stainless Steel with Hairline Finish
Indicator:
Orange Dot-Matrix LED
Buttons:
Push buttons

FX-k11



Faceplate: (Swing Type)
Stainless Steel with Hairline Finish
Indicator:
Multicolor LCD Screen (7 inch)
Buttons:
Push buttons

FX-k12



Faceplate: (Swing Type)
Stainless Steel with Hairline Finish
Indicator:
Multicolor LCD Screen (10.4 inch)
Buttons:
Push buttons

FX-k13



Faceplate: (Swing Type)
Stainless Steel with Hairline Finish
Indicator:
Monochrome LCD Screen (7 inch)
Buttons:
Push buttons

FX-m1



Faceplate: (Swing Type)
Stainless Steel with Hairline Finish
Indicator:
Multicolor LCD Screen (10.4 inch)
Buttons:
Push buttons

FX-m3



Indicator:
7 inch color LCD screen, will be intuitive access to a variety of elevator operation content and provide auxiliary operation information.

Digital combination of floor selection login operation is easy to understand and more suitable for high-rise elevator operation.

Confirmation button for the selection

FX-g31



Note: The maximum floor buttons shall be 40 buttons.

The thickness is 20mm



■ Standard ■ Optional

Wall-mounted Type

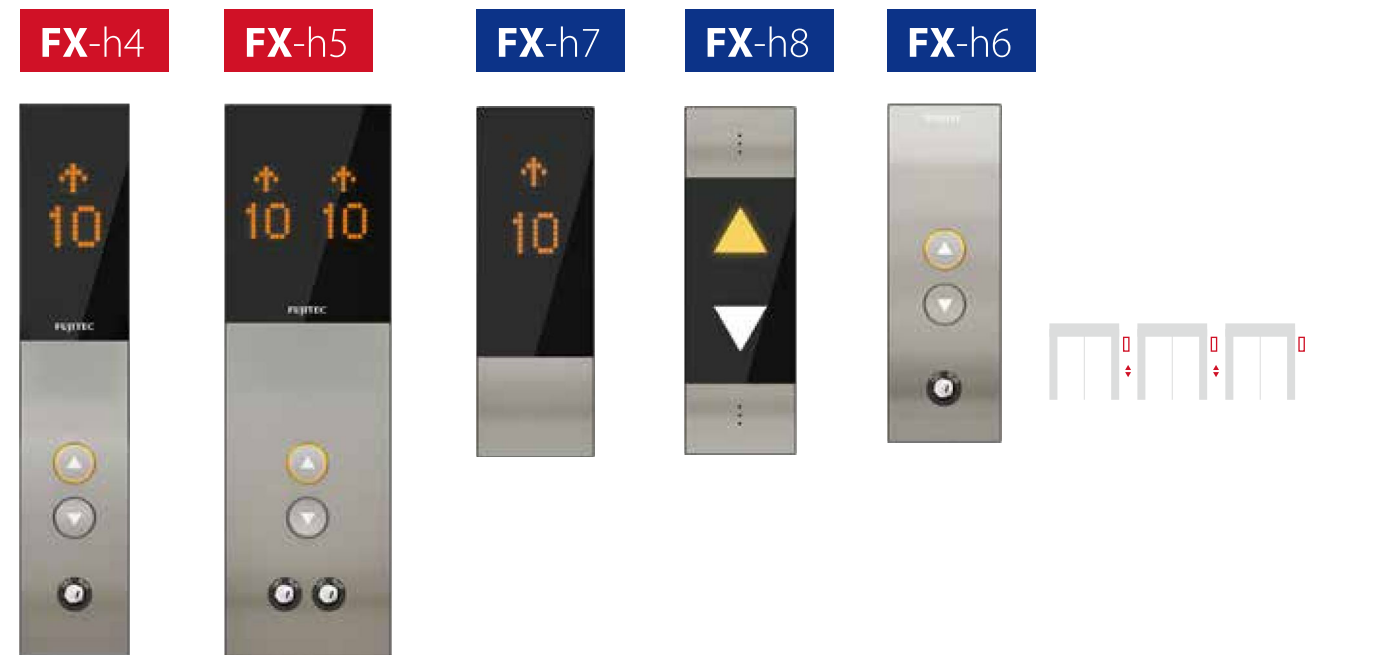

Faceplate:
 Stainless Steel with Hairline Finish/ Acrylic Resin
 Indicator:
 Orange Dot-Matrix LED
 Multicolor LCD Screen (4.2 inch)
 Monochrome LCD (4.1 inch)
 Buttons:
 Push buttons

Inserted Box Type



Faceplate:
 Stainless Steel with Hairline Finish
 Indicator:
 Orange Dot-Matrix LED
 Multicolor LCD Screen (4.2 inch)
 Monochrome LCD (4.1 inch)
 Buttons:
 Push buttons

■ Standard ■ Optional



FX-k74

Size (mm)
L440x W90 x H8
Indicator
LED
Lighting Color
White



FX-k75

Size (mm)
L440 x W100 x H14.5
Indicator
LCD (4.3 inch)
Lighting Color
Yellow



FX-k8

Size (mm)
L60 x W200 x H46
Lighting Color
Yellow



FX-k82

Size (mm)
L55x W422 x H46.5
Lighting Color
Yellow



FX-k81

Size (mm)
L55 x W422 x H26
Lighting Color
Yellow

Note: Hall Button + Hall-Lantern combination without the Hall (Digital/ LCD) Indicator is recommended when 4GSO-8GSO* is operated by the <Immediate Announcement System of a serving Car> function is applied by FLEX-NX (200 & 300).
(* GSO = Group Supervisory Operation)

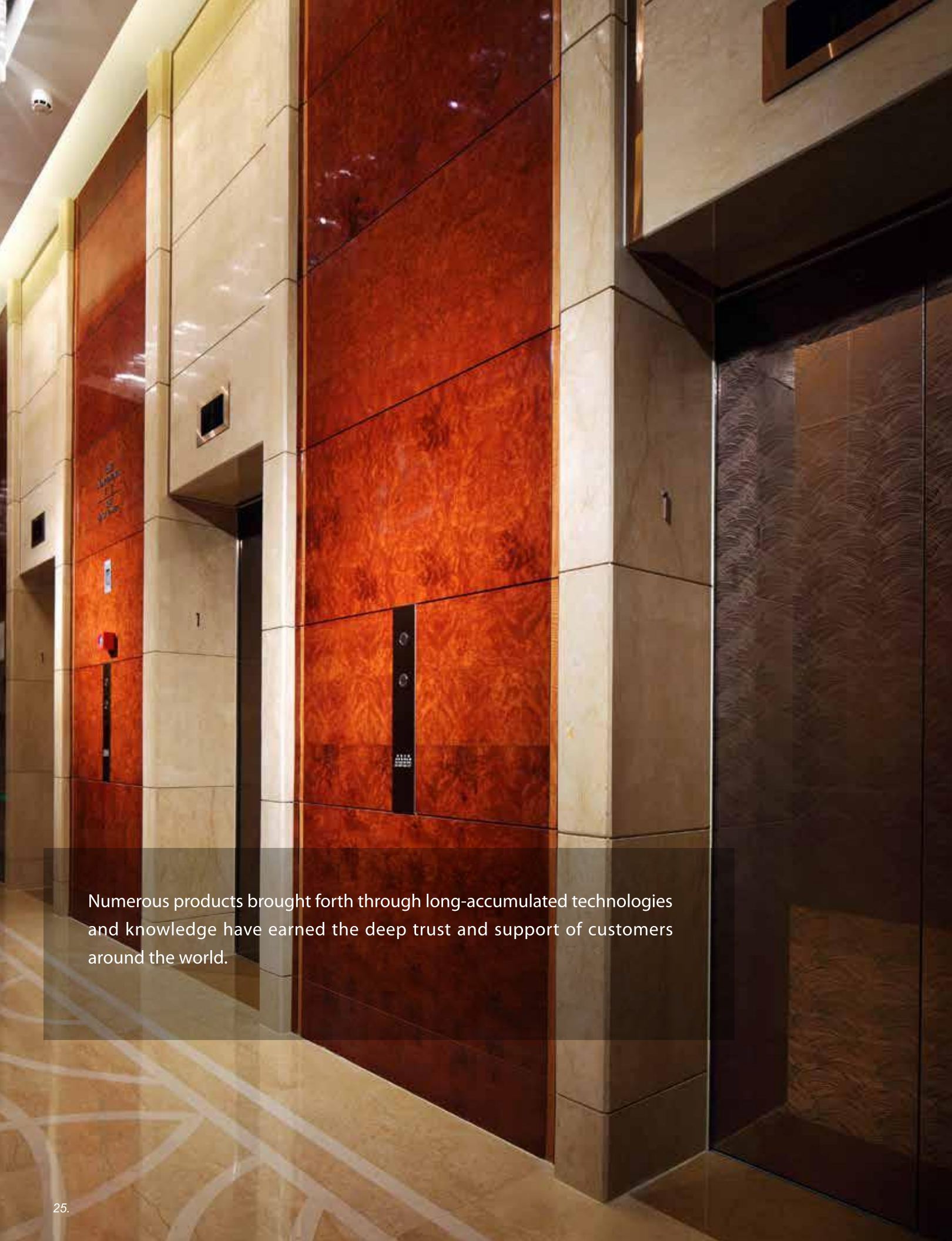

Numerous products brought forth through long-accumulated technologies and knowledge have earned the deep trust and support of customers around the world.

TE-a9		TE-a7		Ceilings, Car Panels, Car Doors, Landing Doors, and Jamb: Paint <small>Note: The colors of TE-f1 and TE-f2 are optional. *Actual colors may differ from the images.</small>
TE-f1		TE-b1		
TE-f2		TE-b2		
YS-001	YS-004	YS-007	YS-008	Car Panels, Car Doors, and Landing Doors: Stainless Steel with Etching <small>*The dimensions of an actual pattern differ from the images.</small>
YS-015	YS-025	YS-026	YS-059	
BD-b1	BD-b2	BD-b3	BD-b4	Car Floor (Vinyl Tile) <small>*The scale and color of an actual design differs from the images.</small>
BD-b5	BD-b6	BD-b7	BD-b8	

Systems & Functions

ELSIA Main Specifications

Capacity

1050, 1200, 1350, 1600, 2000 kgs

Speed

3.0, 3.5, 4.0, 5.0, 6.0, 7.0, 8.0 mps

Number of Served Floors

56 Stops or Less

Travel Height

400m

Note:

Speed(m/s)	Maximum Travel Height(m)
3.0-4.0	200
5.0	250
6.0	300
7.0-8.0	400

Control Method

VVVF controlled by distributed 32-bit Microcomputers.

Traction Machine

Gearless Machine with Permanent Magnetic Synchronous Motor

Types of Elevator Operation

1-Car or 2-Car Selective Collective Operation or Group Control Operation for 8 Cars in a Bank

Door Operation System

Permanent Magnetic Gearless Motor controlled by VVVF

Door Opening Type

2-Panel Center Opening

1. Elevator Operation Control System

Control Systems	Details of the Systems
For One Elevator: 1-Car Selective Collective Operation (Simplex)	Landing calls in the direction in which the elevator is traveling are served sequentially. After all the landing calls are served, landing calls in the opposite direction will be served. When there are no incoming calls, the elevator stops and stays at the last served floor.
For Two Elevators in a Bank: 2-Car Selective Collective Operation (Duplex)	Two selective-collective-operation elevators work together in one group. Landing calls are served by either elevator that can respond first. When there are no calls, one will be on standby at the main floor; the other will stay at the last served floor.
For Three to Eight Elevators in a Bank (Group Control Operation)	The operation of more than two elevators in a bank is controlled by a group supervisory system which calculates passenger waiting time in advance based on the accumulated traffic data, such as passenger travel patterns and passenger volume at each floor, etc.

2. Functions and Specific-Purpose Operations, etc.

Functions and Specific-Purpose Operations, etc.	Details	●: Standard / ■: Optional		
Passenger-Safety Functions	Alarm Buzzer	When the emergency button is pressed, the car-top-mounted buzzer will sound an alarm.	●	
	Rescue Operation to Nearest Floor	In the event that an elevator stops between floors, a safety circuit will automatically analyze the situation and slowly move the elevator to the nearest available floor.	●	
	Automatic Releveling	In the event that an elevator floor isn't leveled with the landing floor, the Automatic Releveling function will initiate and make the elevator floor flush with the landing floor.	●	
	Emergency Car Lighting	In the event of a power failure, a self-charging-battery-equipped emergency lighting system will light up the elevator for passenger safety and relief.	●	
	Five-Way Intercom	An intercom for 5-way communication is installed in the elevator. It allows 4 remote telephones to communicate with the elevator; one on the car top, one in the pit, one in the machine room and one in the building-system control room.	●	
	Multi-Beam Sensor	A multi-beam sensor emits multiple infrared beams, which will scan at the high speed in the elevator door, forming an infrared beam barrier. If a single beam is interrupted, the sensor will stop the closing doors and reopen them.	●	
	Multi-Beam Sensor with Mechanical Safety Edge	A multiple-beam sensor can be incorporated in mechanical safety edges of elevator doors.		■
	Night-Time Self-Checking Operation	During the night time when the elevator doesn't receive any car and hall calls, the system will move the elevator and check the mechanical brake conditions automatically.	●	
	Open Door Warning	If a passenger tries to forcibly open the doors while the elevator is in operation, the warning device will sound an alarm.	●	
	Unintended Car Movement Protection (UCMP)	The Unintended Car Movement Protection system prevents elevator movement from the landing floor, while passengers are entering and getting off the elevator.	●	
	Car Door Anti Stripping Device	It can prevent passengers from falling into the shaft when the door is opened in the non unlocking area, and further ensure the safety of elevator passengers.	●	
	Impact Resistant Door System	The impact resistance of the landing door system is further strengthened, and the risk of falling into the shaft caused by the impact of the landing door system is effectively prevented, further ensuring the safety of elevator related personnel.	●	

The above functions may change without prior notice.

Systems & Functions

Functions and Specific-Purpose Operations, etc.		Details	● : Standard / ■ : Optional	
Efficient-Operation Functions	Anti-Nuisance Function	1) For elevators with three or more landings, when three or more car calls are registered at the same time, or when four or more car calls are registered in an extremely short period of time, the system will automatically cancel the activated car calls. 2) For elevators with five or more landings, when an elevator loaded with 100 kg or less receives four or more car call registrations, the system will cancel all the activated registrations.	●	
	Auto Adjustment of Door Open Time	This function automatically adjusts the door-hold open time (dwell time) at each floor depending on passengers' hall- and car- call registration situations.	●	
	Automatic Return to Main Floor (for 1-Car & 2-Car & Group Control Operation)	When an elevator does not receive any car- or hall- calls for a certain period of time, the Automatic Return to Main Floor function makes the elevator go to the lobby or a predetermined floor and waits in standby for passengers to board.	●	
	Door Nudging	If the car doors are held open over a given period of time, the Door Nudging function will close them slowly with an audible alarm.	●	
	Auto-Separation after Elevator Failure (for Group Control Operation)	When an elevator under group control operation fails to operate normally, it will be separated from the elevator group so as not to affect the overall group elevator performance.	●	
	Load Bypass	When a traveling car is fully loaded, it will bypass floors where hall calls are registered. Those hall calls will be assigned to another available elevator.		■
	Overload Warning	When a car becomes overloaded, the warning alarm will sound. The elevator doors will not close until the overloaded state is resolved.	●	
	Reverse-Direction Car-Call Cancellation	In the event that a passenger tries to register a car call that is behind the car's current travelling direction, the elevator system will regard it as a nuisance call and ignore it in order to maintain the elevator service efficiency.	●	
	Wrong Car-Call Register Cancellation	In case a passenger presses the wrong car call button, this mistake can be cancelled by pushing the same button twice.	●	
	Door Open Holding Button (COB)	In order to meet the demand of loading and unloading goods, a door opening extension button is installed on the operation panel in the car. Pressing this button can keep the door opening time for 3 minutes.		■
Passenger-Comfort Functions	Arrival Chime (In Car)	When a car arrives at a destination floor, an arrival chime will sound softly.		■
	Attendant Operation	By using attendant-operation buttons inside a car operating board's cabinet, authorized personnel can register car calls for in-car passengers. In addition to monitoring incoming hall calls, the attendant decides the car travel direction and operates the car doors with priority service for in-car passengers.	●	
	Automatic Voice Announcement System (VONIC)	A computerized voice system provides passengers with timely information about car directions, car arrivals, door opening and closing, and emergencies, etc. At the customer's request, announcements in other languages can be added.	●	
	Plasmacluster™ Ion Generating Device (IONFUL)	Plasmacluster Ion Generating Device to be built into a car's ventilation unit creates clean air for passenger comfort by disinfecting germs, odor molecules, bacteria, viruses, and allergens in the elevator.		■
	Visual Display on Car Operating Board	Informing on an elevator's current condition, a visual display on the car operating board will provide passengers with timely text messages such as "OVERLOADED", "EMER. OPERATION", "PLEASE EXIT THE ELEVATOR." etc.	●	
	Visual Display on Landing Fixture	Informing on an elevator's current condition, a visual display on the landing fixture will provide waiting passengers with timely text messages such as "OVERLOADED", "EMER. OPERATION", etc.	●	

Functions and Specific-Purpose Operations, etc.		Details	● : Standard / ■ : Optional	
Energy-Saving Functions	Automatic Fan and Light Control	If an elevator receives no car- and hall- calls within a certain period of time, its ventilation fan and lights will turn off automatically.	●	
	Parking Operation	When an elevator is shifted to Parking Operation mode, the elevator will move to the pre-assigned floor and park with its doors closed, and car lights and fan turned off.		■
Specific-Purpose Operations	Battery-Powered Automatic Landing Operation (LANDIC)	In the event of a power failure, a compact battery power source will move the car to the nearest available floor.		■
	Door Opening Failure Rescue Operation	When an elevator fails to open the doors at a landing floor, it will move to the next available floor and open them.	●	
	Earthquake Rescue Operation (WAVIC)	When a seismic sensor has detected a seismic wave (the secondary seismic wave), the elevator(s) will be shifted to rescue operation mode and automatically move to the nearest available floor for passenger evacuation.		■
	Fire Operation	In the event of a fire, the Fire Operation mode will automatically take an elevator directly to an evacuation floor and immobilize it there. (One refuge floor at the terminal floor)	●	
	Fireman Operation	Under automatic operation, when the Fireman's switch is on, the car will immediately cancel all the calls and run to the refuge floor. The elevator responds to the call in the car only, which is used for special fire fighting operation.		■
	Independent Operation	When Independent Operation is turned on, a designated elevator can operate independently for exclusive use.	●	
Equipment for Building Security, etc.	CCTV-Camera Cables (Coaxial type, Network cable and Optical fiber)	For a CCTV camera, video-signal cables suitable for the hoistway and / or machine room are available.		■
	Building-Management-System (BMS) Interface	Through a purpose-built interface, a building management system can receive up-to-date elevator operation data.		■

The above functions may change without prior notice.

Standard Specification (Wall-Mounted)

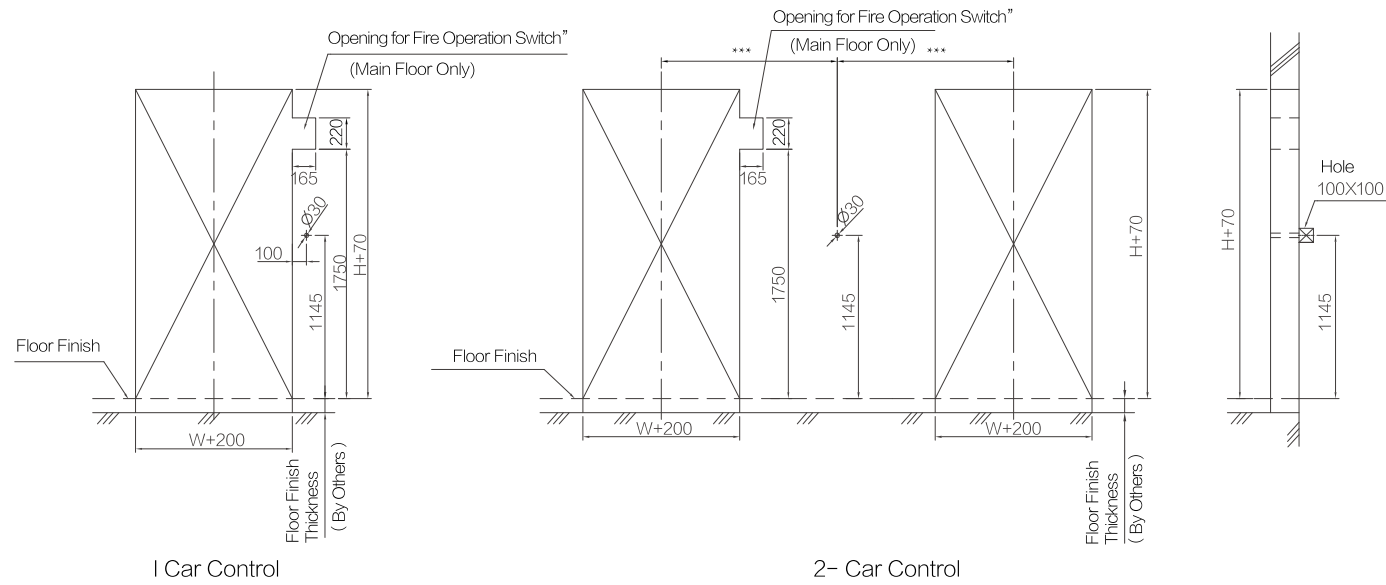

Optional Specification (Inserted)

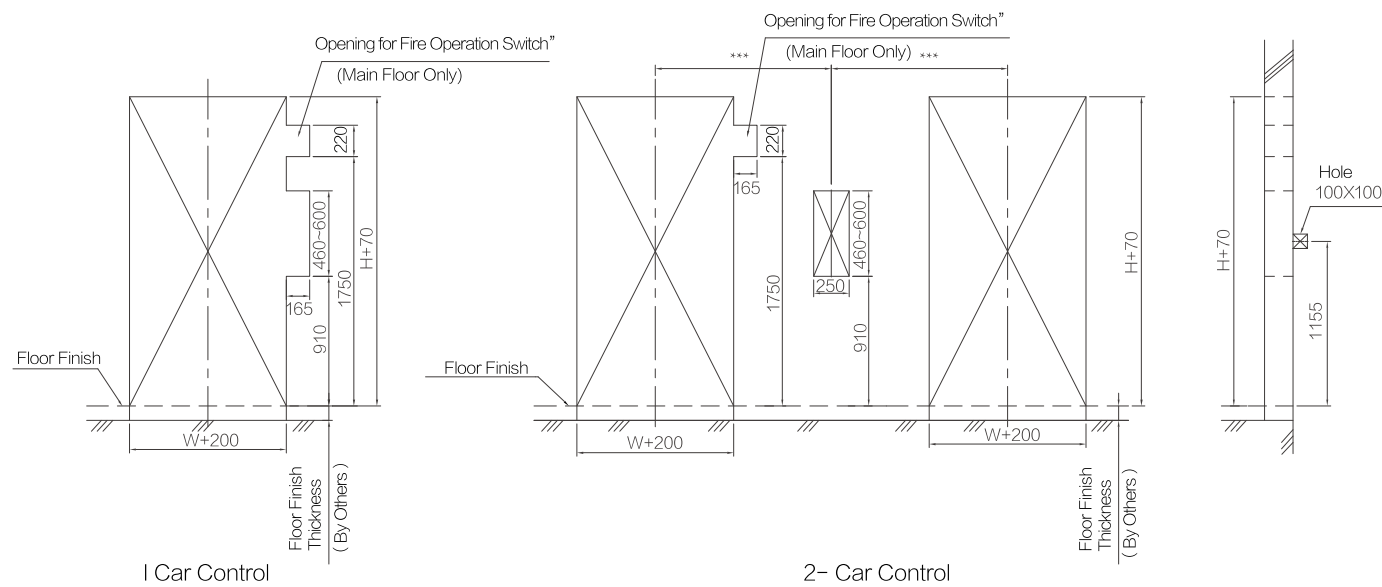

Relevant Dimensions

Capacity (kg)	Speed (m/s)	Opening Type	Car Inside A x B (mm)	Opening W x H (mm)	Two Parallel Hoistways X x Y (mm)	Machine Room Size MX x MY x MH (mm)	Pit Depth P (mm)	Overhead OH (mm)
1050	3.0	2CO	1600 x 1500	900 x 2100	4500 x 2300	4500 x 3600 x 2600	3100	4910
	3.5				4500 x 2300	4500 x 3600 x 2600	3100	4910
	4.0				4500 x 2300	4500 x 3600 x 2600	3320	5190
	5.0				5100 x 2350	5100 x 3940 x 3400	3490	5400
	6.0				5100 x 2350	5100 x 3940 x 3400	3680	5700
	7.0				5600 x 2500	5600 x 4850 x 3400	4950	6630
	8.0				5600 x 2500	5600 x 4850 x 3400	5570	7590
1200	3.0	2CO	1800 x 1500	1100 x 2100	4900 x 2300	4900 x 3600 x 2600	3100	4910
	3.5				4900 x 2300	4900 x 3600 x 2600	3100	4910
	4.0				4900 x 2300	4900 x 3600 x 2600	3320	5190
	5.0				5100 x 2350	5100 x 3940 x 3400	3490	5400
	6.0				5100 x 2350	5100 x 3940 x 3400	3680	5700
	7.0				5600 x 2500	5600 x 4850 x 3400	4950	6630
	8.0				5600 x 2500	5600 x 4850 x 3400	5570	7590
1350	3.0	2CO	2000 x 1500	1100 x 2100	5300 x 2300	5300 x 3600 x 2600	3100	4910
	3.5				5300 x 2300	5300 x 3600 x 2600	3100	4910
	4.0				5300 x 2300	5300 x 3600 x 2600	3320	5190
	5.0				5500 x 2380	5500 x 3940 x 3400	3490	5400
	6.0				5500 x 2380	5500 x 3940 x 3400	3680	5700
	7.0				5600 x 2500	5600 x 4850 x 3400	4950	6630
	8.0				5600 x 2500	5600 x 4850 x 3400	5570	7590
1600	3.0	2CO	2000 x 1700	1100 x 2100	5300 x 2500	5300 x 3800 x 2600	3100	4910
	3.5				5300 x 2500	5300 x 3800 x 2600	3100	4910
	4.0				5300 x 2500	5300 x 3800 x 2600	3320	5190
	5.0				5500 x 2580	5500 x 4140 x 3400	3490	5400
	6.0				5500 x 2580	5500 x 4920 x 3400	3680	5700
	7.0				5600 x 2700	5600 x 5050 x 3400	4950	6630
	8.0				5600 x 2700	5600 x 5050 x 3400	5570	7590
2000	3.0	2CO	2000 x 2000	1100 x 2100	5300 x 2800	5300 x 4100 x 2600	3100	4910
	3.5				5300 x 2800	5300 x 4100 x 2600	3100	4910
	4.0				5300 x 2800	5300 x 4420 x 2600	3320	5190
	5.0				5500 x 2880	5500 x 5220 x 3400	3490	5400
	6.0				5500 x 2880	5500 x 5220 x 3400	3680	5700
	7.0				5600 x 3000	5600 x 5350 x 3400	4950	6630
	8.0				5600 x 3000	5830 x 6190 x 3400	5570	7590

Notes: 1. The data shown above may vary based on elevator specification arrangement.
 2. Refer to the Work Done by Others for the Acceptable Inclination of Hoistway's Vertical Centerline.
 3. In case of single hoistway, pre-inquiry is necessary to take the measures for reducing the noise in the car.

Power Supply Data

Capacity (kg)	Speed (m/s)	Motor Power (kW)	Rated Current (A)	Acceleration Current (A)	Equivalent Current (A)	Power Capacity (kVA)	Open-Circuit Current (A)	Allowable Maximum Length of Main Power Feeder Line(m)										Heat Generation Rate in Machine Room(KJ/h)	Air Ventilation Rate in Machine Room(m³/h)
								35sq	50sq	70sq	95sq	120sq	150sq	185sq	240sq	300sq			
1050	3.0	28	87	197	37	33	80	88	115	156	201	283	340	398	484	510	19800	2330	
	3.5	32	99	243	47	37	100	—	93	126	162	228	274	321	391	411	23100	2720	
	4.0	37	112	278	53	43	100	—	81	110	142	200	240	281	342	360	26400	3110	
1200	3.0	28	97	229	43	33	80	75	98	133	172	242	291	341	415	436	22650	2670	
	3.5	32	111	265	50	37	100	—	85	116	149	210	252	296	359	378	26400	3110	
	4.0	37	125	302	57	43	125	—	—	101	131	184	221	259	314	331	30150	3550	
1350	3.0	28	107	235	43	33	100	—	96	130	168	236	283	332	404	425	25450	3000	
	3.5	32	123	286	53	37	100	—	79	107	138	194	233	273	332	349	29700	3500	
	4.0	37	139	316	58	43	125	—	—	97	125	175	211	247	300	316	33950	4000	
1600	3.0	41	120	249	44	47	100	—	91	123	159	223	268	314	382	402	30150	3550	
	3.5	48	135	276	48	55	125	—	—	111	143	201	242	284	345	363	35200	4140	
	4.0	54	154	333	59	62	125	—	—	92	118	166	200	234	285	300	40200	4730	
2000	3.0	41	146	293	51	47	125	—	—	104	135	189	227	266	324	341	37700	4440	
	3.5	48	166	340	59	55	160	—	—	—	—	163	196	230	279	294	44000	5180	

Notes: 1. The data shown above may vary based on elevator specification arrangement.
 2. Earthing wires shall be arranged and installed based on local elevator code requirement.

The above dimensions are for reference only. The actual engineering design data shall be used.

Work Done by Others

1. Elevator Machine-Room and Hoistway Environment

Temperature of Machine Room and Hoistway	Temperature of machine room and hoistway shall be kept from 5 °C (41 °F) to 40 °C (104 °F).
Relative Humidity	1. When a temperature reaches at 40 °C (104 °F), the relative humidity does not go beyond 50%.
	2. In the year's most humid month(s), relative humidity shall be kept lower than 90 % and the temperature lower than 25°C (77 °F).
	3. Dew condensation prevention measures shall be taken, if there are the possibilities that condensation form inside and on electrical equipment.

2. Electric Power Source

Type of Power Supply	1. Three-Phase Power Supply for Elevator Driving Machine 2. Single-Phase Power Supply for Lighting Equipment
Allowable Error of Voltage Value	The allowable error of voltage value is 7 % above and below the rated voltage.

3. Acceptable Inclination of Hoistway's Vertical Centerline

Hoistway's Vertical Length	Centerline's Tilt away from the Plumb Line (unit: mm)
30 meter or less	0 to 25 mm or less
More than 30 meters to 60 meters or less	0 to 35 mm or less
more than 60 m	0 to 50 mm or less

4. Work done by Others

The following items are in the scope of other contractors' work, not covering all items done by them.

For Hoistway

1.	Construct solid-state, fire-proof elevator hoistway.
2.	Cut out landing walls for Fujitec's installation of elevator operating fixtures and elevator equipment.
3.	Do wall finishing work by filling cement between jambs and landing walls.
4.	Do wall finishing work by filling cement between landing fixtures and landing walls.
5.	Give water-proofing and drainage treatment in elevator pit including the installation of pumping equipment.
6.	Install space divider screens between respective elevators in a hoistway pit.
7.	Install steel separator beams at regular vertical intervals in a hoistway.
8.	When hoistway is constructed with bricks, put steel lintels in their walls for Fujitec's installation of rail brackets. The steel lintels must be completely fixed inside the walls. The vertical height of the lintel is required to be 300 mm or more. For details, see the relevant drawings.
9.	When an elevator traveling distance from a floor to the next is more than 11 m, make an opening on the hoistway wall between the floors and install emergency exit doors in the opening for passenger evacuation.
10.	It is advised that there is no human access to the space below the hoistway pit.
11.	When the bottom of a hoistway pit is deeper than the required level, add backfill concrete up to the required level.
12.	Provide and install a pit ladder based on the layout drawings.
13.	Provide and install all of electricity supply apparatuses (inclusive of pipes, leads, wires, etc.) from the building's electricity supply system to the hoistway, landing floors and Fujitec-designated locations.
14.	Provide and install electrical outlets in the hoistway.
15.	Install lighting equipment of 30 watt or more at 7-meter intervals inside the hoistway with 0.5-meter clearance at the top and bottom of the hoistway. The lighting intensity is required to be 50 lux or more at the car-top working platform and at the 1-meter high position above the pit bottom.

For Machine Room

1.	Construct solid-state, fire-proof machine room.
2.	Provide and install a power switching / distributing board in the machine room.
3.	Install and lay electrical pipes, wires, and leads in the machine room. They shall be extended from the power switching / distributing board to the controller, machine, and other electrical equipment.
4.	Provide and install all of electricity supply apparatuses (inclusive of pipes, leads, wires, etc.) on various routes from the building's electricity supply system to the machine room and Fujitec-designated locations.
5.	Install lighting equipment in the machine room. The lighting intensity on the machine room's floor is 200 lux or more.
6.	Install air ventilator(s) and/or air conditioner(s) in order to keep the temperature of the machine room between 5 °C (41 °F) and 40 °C (104 °F).
7.	Provide and install electrical outlets in the machine room.
8.	Install fire-proof entrance doors in the machine room.
9.	Take a noise reduction measure, if it is required.
10.	Install smoke detector, if it is required.
11.	Make cutouts and holes in the machine room.
12.	Construct machine room floor of which 1-square-meter area can bear the load of 700 kgs.
13.	Make holes in the walls of a machine room for Fujitec's installation of machine support beams and fill concrete into the gap between the walls and the fixed beams.
14.	After the installation of electrical pipes, wires, and leads, etc. on the machine room floor, lay lightweight concrete and finish the floor surface with dust-resistant material.
15.	Make an appropriate size of opening on the roof or the sidewall of a machine room in order for Fujitec to carry in elevator machine and other equipment.
16.	Install machine lifting hooks and / or steel beams on the ceiling slabs of a machine room. The required lifting load capability is stated on the relevant installation drawings.
17.	Install windows and louvers in order to let in daylight into the machine room.
18.	If a person's entry into the machine room needs a ladder or stairs, the installation and fixation of it or them is required.
19.	In case the machine room has two or more floors and a distance between each floor is more than 500 mm, install a ladder or stairs between the floors. Guardrails shall be provided and installed on the upper floor(s) for the prevention of a person's fall.

Others

1.	Ground-fault interrupter and current leakage alarm are required to be protected against current-harmonic distortion.
2.	Lay building's telecommunication lines 500 mm away from the electric feeder lines for elevator system.
3.	Remove corroded metal materials from the machine room and the hoistway.
4.	Protect the machine room and the hoistway against hazardous gas.
5.	Prevent dust from accumulating in the hoistway and the machine room.
6.	Provide a storage room in order to stock elevator parts and installation materials.
7.	Do not place any tools and materials not related to elevators in the hoistway and the machine room.

1 2 4 5 7 8 9 10

3 6

- ① New York Times Tower
- ② Wangjing SOHO
- ③ China World Trade Center
- ④ HSBC Headquarters
- ⑤ The Cullinan
- ⑥ VIA 57 West
- ⑦ Shangri-La Hotel, Yiwu
- ⑧ 1717 Broadway-Courtyard & Residence Inn by Marriott
- ⑨ Guizhou Great Hall of the People
- ⑩ Snowland Project

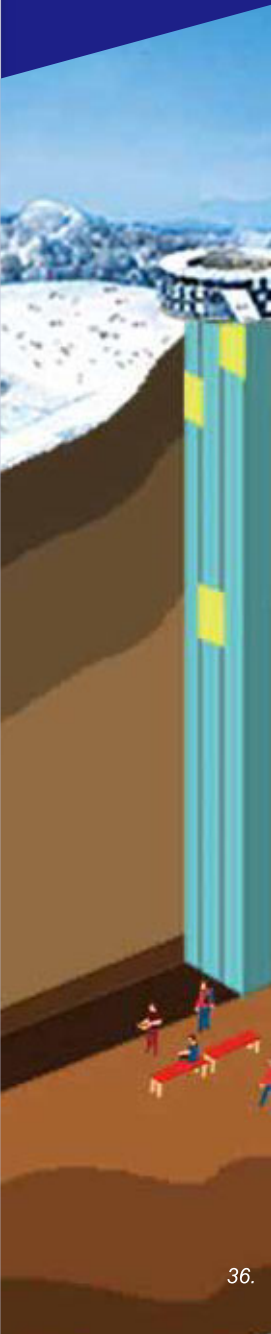
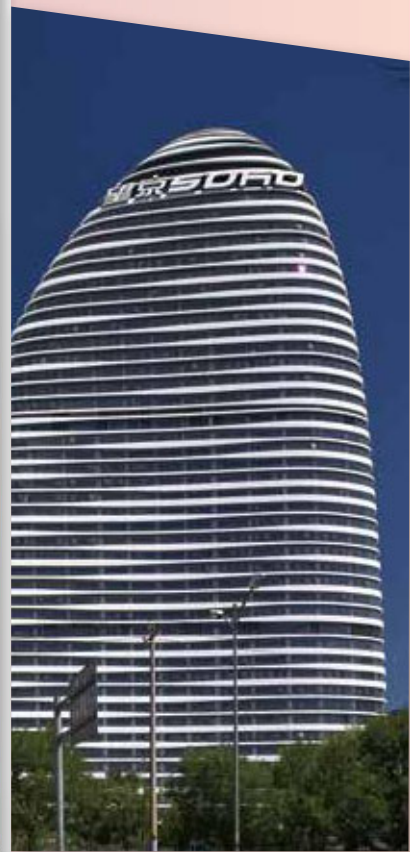

Fujitec Global Operations



Ohaio Plant(U.S.A)



Langfang Plant(China)



Shanghai Plant(China)



Korea Plant



Taiwan Plant



Big Wing (Group Headquarters in Japan, Elevator Plant)



Shingapore Plant



India Plant



North & South America

FUJITEC AMERICA, INC.
 FUJITEC CANADA, INC.
 FUJITEC VENEZUELA C.A.
 FUJITEC ARGENTINA S.A.
 FUJITEC URUGUAY S.A.

Japan

FUJITEC CO.,LTD.

East Asia

FUJITEC (HK) CO., LTD.
 FUJITEC TAIWAN CO.,LTD.
 FUJITEC KOREA CO.,LTD.
 HUASHENG FUJITEC ELEVATOR CO.,LTD.
 SHANGHAI HUASHENG FUJITEC ESCALATOR CO.,LTD.
 FUJITEC SHANGHAI TECNLOGIES CO.,LTD.
 FUJITEC SHANGHAI SOURCING CENTER CO.,LTD.

Europe & Middle East

FUJITEC UK LTD.
 FUJITEC SAUDI ARABIA CO.,LTD.
 FUJITEC EGYPT CO.,LTD.

South Asia

FUJITEC SINGAPORE CORPN. LTD.
 FUJITEC INC.(PHILIPPINES)
 FUJITEC (MALAYSIA) SDN, BOD.
 P.T. FUJITEC INDONESIA
 FUJITEC VIETNAM CO., LTD.
 FUJITEC INDIA PRIVATE LTD.
 FUJITEC (THAILAND) CO., LTD.
 FUJITEC LANKA(PRIVATE) LTD.
 FUJITEC PACIFIC, INC.(GUAM)
 FUJITEC MYANMAR CO., LTD.